

Stress distribution of implant retained obturators using different types of attachments: A three dimensional finite element analysis

M.M. Amer*, H.A. Rashad*, S. Abdallah*

Prosthodontic Department, Faculty of Dentistry, Tanta University, Egypt

Received 24 November 2014; revised 13 September 2015; accepted 21 September 2015

Available online 2 November 2015

Abstract

Objectives: The objective of this study was to analyze the stress distribution around dental implants for different designs of implant supported obturator in cases of midline maxillary defect using a 3-dimensional finite element analysis.

Methods: A model of edentulous patient with midline maxillectomy is transferred to digital (CAD) model using 3D coordinate measuring machine. Finite element models were formed using ABAQUS package, creating 3 models rehabilitated with different designs of implant retained obturator prostheses using different attachment types of dental implants in the alveolar bone on the unaffected side, three implants with ball & socket, magnet and bar & clips. A 100 N load was applied bilaterally vertically and unilateral vertically and obliquely on the defect side, and von Mises stresses in the cortical bone around implants were evaluated and compared.

Results: All the models showed the highest stress values under oblique load that applied on the defect side around the most anterior implant, the ball & socket models exhibited the lowest stresses followed by the magnet then the bar & clips models which showed the highest stress values.

© 2015, Hosting by Elsevier B.V. on behalf of the Faculty of Dentistry, Tanta University.

Keywords: Attachment; Dental implant; Obturator prosthesis; Stress distribution; Three-dimensional finite element analysis

1. Introduction

The rehabilitation of maxillary defects is very important in improving physiological functions, facial appearance and living quality of patients. Obturator prosthesis continues to be the preferred method for rehabilitation for most maxillectomy patients. On the

other hand, when surgical reconstructive procedures are performed, maxillofacial prosthetic treatment is still indicated for restoration of normal oral function in most maxillectomy patients [1].

The goals of prosthetic rehabilitation for total and partial maxillectomy patient include separation of oral and nasal cavities to allow adequate deglutition, articulation and mastication, restore mid-facial contour and acceptable esthetic results, however the most important objective is preservation of the remaining teeth and tissue [2].

The cooperation between the prosthodontist and surgeon is essential for successful treatment. A favorable defect must be designed at the time of tumor

* Corresponding authors.

E-mail addresses: marwa.lolo@yahoo.com (M.M. Amer), hodaamin@hotmail.com (H.A. Rashad), saeed.abdullah14@yahoo.com (S. Abdallah).

Peer review under the responsibility of the Faculty of Dentistry, Tanta University.

removal to provide proper support and sufficient retention and stability of the obturator for the prosthesis to function adequately. In dentate patients, these requirements are easily met by relying on the remaining dentition, retentive tissue undercuts, and support areas within the defect [3,4]. However, the construction of a maxillary obturator for an edentulous patient can be challenging as the obturator exhibits varying degrees of movement depending on the amount and contour of the remaining palatal shelf, height of the residual alveolar ridge, size of the defect, and availability of undercuts [4].

Many ingenious techniques have been developed to manage the problem of retention and stability of the maxillary obturator including maximizing its extension over less displaceable tissues, linking sectional components together with magnets or precision attachments so as to produce a relatively immobile device and the use of traditional aids to retention such as springs and adhesives [5].

Placement of implants can have a dramatic effect on the stability and retention of the prosthesis, particularly in edentulous maxillectomy patients. The residual premaxillary segment generally provides adequate volume and density of bone for the placement of implants. Alternative sites include posterior alveolar ridge, and the zygoma are included [3].

Regarding the biomechanical loads on implants many techniques such as the use of mathematical calculations [6,7], photo-elastic stress analysis [8,9], two- or three-dimensional finite element stress analysis [10,11] and strain-gauge analysis (SGA) [12,13] can be used. Since an almost actual representation of stress behaviors can precisely be provided, three dimensional finite element stress analysis (3D FEA) has been introduced as a superior theoretical tool [14].

Finite element model allows better understanding of stresses along the surfaces of an implant and in surrounding bone. This will aid in the optimization of implant design and placement of the implant into the bone; it will also help when designing the final prostheses to minimize stresses [15].

Many investigators evaluated the use of different types of attachment used with implant supported overdenture [12,13]. However, there is lack in the studies that compare the influence of the type of attachment on the stress distribution in cases of implant supported obturator prosthesis.

Therefore this research will study stress produced by obturator prosthesis retained with different types of attachments.

2. Material and methods

Impression of a maxillary completely edentulous patient having an acquired defect was made using silicone based impression material,¹ poured with auto-polymerized acrylic resin.² All modeling procedures are performed using PTC CREO parametric CAD/CAM package to create three dimensional models representing the cancellous, cortical bone, mucosa, denture base, artificial teeth, titanium implant and attachments. The modeling procedures are explained as follow:

2.1. Three dimensional modeling

2.1.1. Modeling of maxilla

The acrylic model is performed using 3D digitizer called 3D coordinate measuring machine CMM.³ This machine measure the 3D dimensions using contact principal, as the touching probe measure each point touched on the measuring surface.

2.1.2. Creating the digital (CAD) model

The 3D points arranged in data file that imported to CAD package. The file format used to enter measured data to CAD package is DXF format. The measuring points are then transformed into surface facets then the surface was smoothed. Then the mucosa was created based of the outer surface of the maxilla with mean thickness 1–3 mm as shown in Fig. 1.

2.1.3. Creating the space for the maxillary sinus and nasal cavity

The defected side of the maxilla was removed, and then a space for the maxillary sinus and nasal cavity was created in the healthy side as shown in Fig. 2.

The maxilla was represented as a combination of cortical and cancellous bone, the bone width at the implant locations was measured and the length of bone was measured too from the crest of the ridge to the floor of maxillary sinus and nasal cavity to determine the diameter and length of implant used. At least 1 mm bone around the neck of implant was maintained and 1 mm between the implant end and the sinus floor.

¹ Zhermack, 45021, Badia Polesine-RO-Italy.

² Acrostone, England, Co.

³ ABERLINK CMM, AXIOMTOO, Aberlink Innovative Metrology LLP. England.

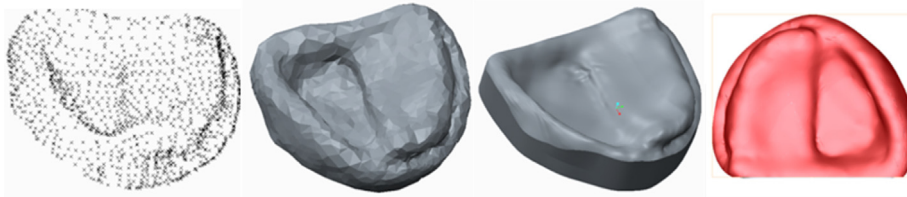

Fig. 1. Generation of key points of the model, measuring points are transformed into surface facets, smoothing of the surface, Creation of the mucosal layer.

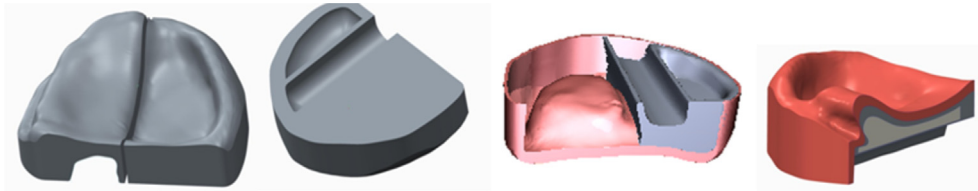

Fig. 2. Creation of maxillary sinus and nasal cavity.

2.1.4. Modeling of implants and attachments

The dental implant selected for this study is the Dyna⁴ implant system. The implant is modeled using appropriate dimensions as given by the manufacturer as shown in Fig. 3.

Three types of attachment were used (ball and socket – magnet – bar and clips), the magnetic attraction of the magnet is 5 N (N).

2.1.5. Modeling of the denture

The teeth assembled with the denture, each tooth is modeled independently according to its dimensions using imaging via camera and modeled in the same way that used with the original surface of the acrylic model, and the obturator at the defect side was made hollow as shown in Fig. 4.

The geometric models are formed by assembly of the bone, mucosa, implants, denture and the three different attachments building up three models as mentioned above.

Three implants are used in these regions, at lateral incisor length 11.5 diameter (Ø) 3 mm, first premolars 10 mm Ø3.6 mm and the second molar 10 mm Ø4 mm were used.

Model I: Ball and socket attachment were used

Model II: Magnet and magnet keeper

Model III: 3 bar abutments are screwed on the implants and the casted bar connecting is cemented on the abutments, clips are fitted in the fitting surface of denture as shown in Fig. 5.

2.2. Creation of finite element model

These models were then imported into (FEA software) to create the FE models.

In this step each component of the FE models was discretized (meshed) into a mesh of smaller and simpler elements connected at their nodes; in this study, the 4-nodes tetrahedral elements (C3D4) were used as shown in Fig. 6.

The stress distribution in the region of cortical bone around the implants is of great interest. Hence, the number of elements in these parts should be big enough to obtain accurate result (**Adapted meshing**). The mesh was tested and refined in the areas of interest until the response did not change significantly.

The number of elements and nodes in each component is listed in Table 1.

2.3. Interface conditions

The interface between implant and bone was modeled as a continuous bond. This implies an ideal osseointegration, without any relative motion at the interface. In other words, the implants were rigidly anchored in the bone, showing a fixed and same type of bond at all material interfaces.

2.4. Boundary conditions

Models were constrained in all directions at the nodes on the base of the cortical bone.

⁴ Dyna Dental Engineering, Netherlands.

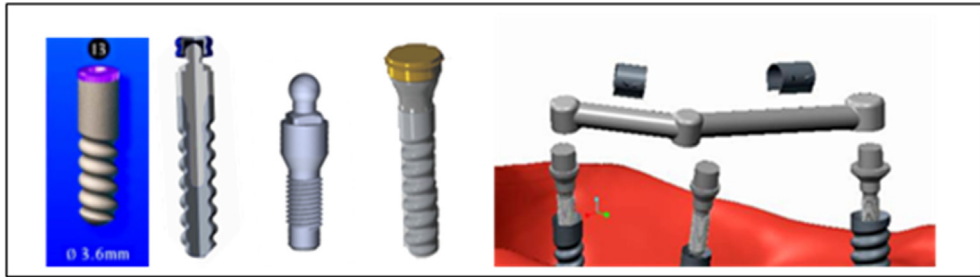

Fig. 3. Three dimensional modeling of the implant fixture and different attachment (ball & socket, magnet, bar & clips).

2.5. Loading conditions

In this step location, orientations, and magnitudes of the forces applied to the prosthesis were identified.

In this study, three different loading condition are considered, Loading involved the application of a simulated bite force as a distributed vertical load of 100 N to the occlusal surface of posterior teeth bilaterally, vertical load of 100 N unilaterally at the non-defective side [16].

The load was distributed over the artificial teeth as (50 N on the first molar, 20 N on each premolar and 10 N on the canine). The oblique load is 45° to the slope of buccal cusps of posterior teeth, it is analyzed to 2 components in y, z axis according to the equation ($F_z \cos 45$ and $F_y \sin 45$) so that 50 N is analyzed to (34, 34), 20 N (14, 14) and 10 N (7, 7) in z, y axis as shown in Fig. 7.

2.6. Material properties

All material used in this study were considered to be isotropic, homogeneous and linearly elastic [19]. The elastic properties of cortical bone, cancellous bone, mucosa, acrylic resin, gold alloy, rubber ring and titanium alloy are given in Table 2.

The 3-dimensional finite element processing program ABAQUS version 6.10 was used to perform the

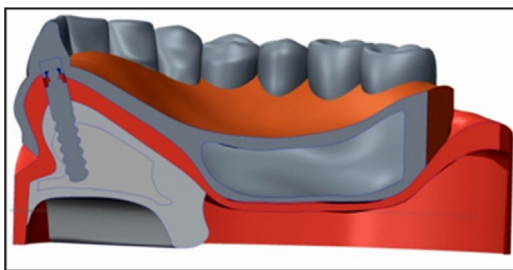

Fig. 4. Three dimensional modeling of the model, implant and obturator.

analysis for each loading condition. Von Mises' equivalent stresses were produced numerically and colour-coded.

3. Results

The result of each of the loading conditions for each of the 3 models are presented in von Mises' equivalent stresses (σ_{equ}) because von Mises' equivalent stresses are most commonly reported in Finite Element Analysis studies to summarize the overall stress state at a point. So that the researcher can quickly determine the most dangerous area in the model [10].

3.1. Outcome of model I (Obturator retained by three implants with ball and socket attachment)

Von Mises stress in model I is shown in Fig. 8 under bilateral vertical forces on both sides and unilateral vertical, oblique forces on the defect side. The highest von Mises stresses value 40.25 MegaPascal (Mpa) was determined in the third load condition (oblique load on defect side) and was recorded at the mesiopalatal surface of the cortical bone around the first implant and was higher than caused by the first and second loading conditions. The highest stress values resulted from the first and second loading conditions and were 32.14 Mpa and 28.96 Mpa, respectively. The Maximum stresses on the second implant was 16.77 Mpa, located on the palatal surface under the third loading condition which is higher than the first second loading (13.39 Mpa and 12.07 Mpa). The stress at the most posterior implant was small 8.03 Mpa, 7.24 Mpa and 13.42 Mpa respectively.

3.2. Outcome of model II (Obturator retained by three implants with magnet attachment)

Von Mises stress in model II is shown in Fig. 9 under bilateral vertical forces on both sides and

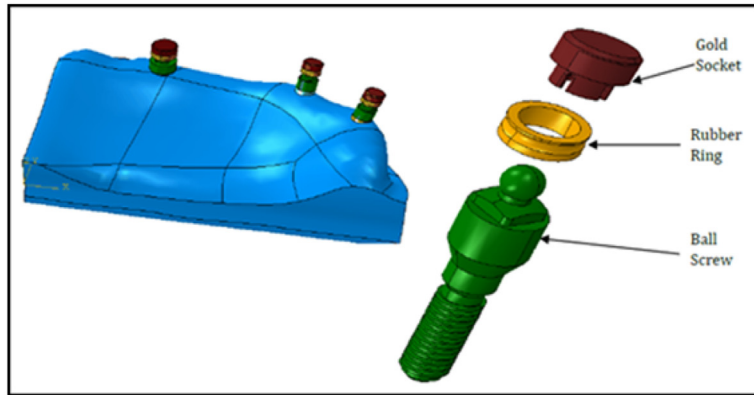

Model: I

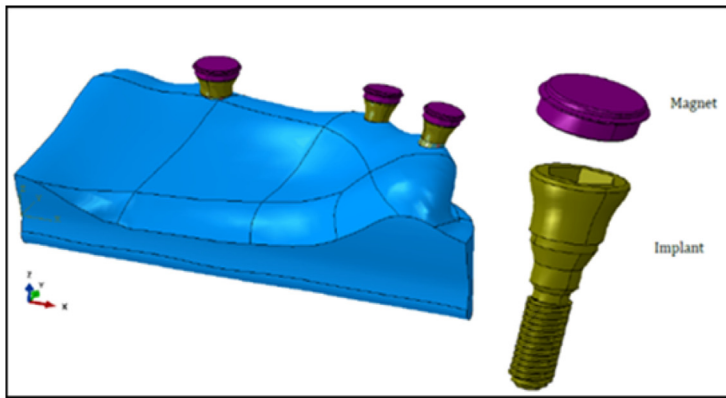

Model: II

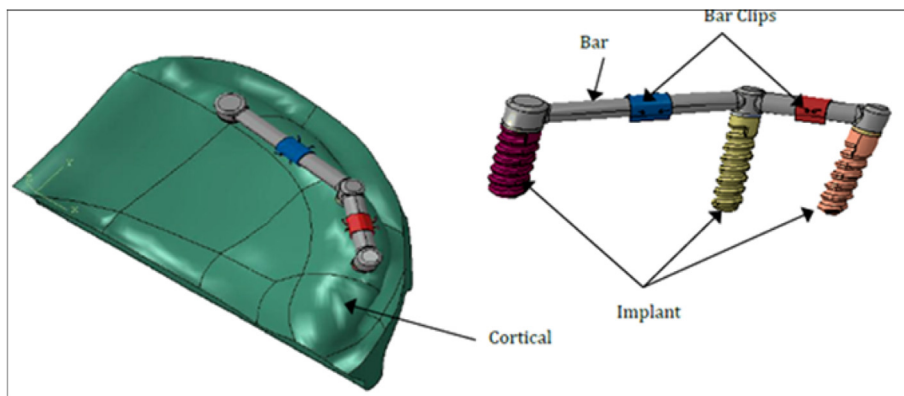

Model: III

Fig. 5. Model I: three implant at 2, 4, 7 positions with ball& socket attachment, Model II:3 implant with magnet attachment, Model III: 3 implant with bar & clips attachment.

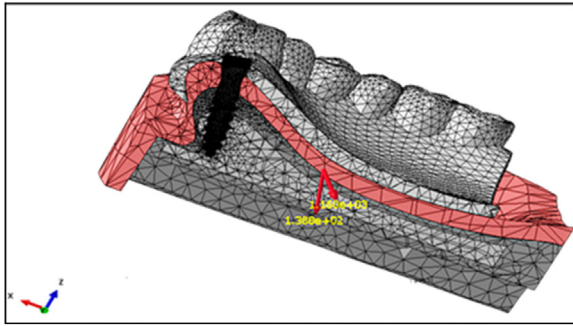

Fig. 6. Meshing of the whole model.

Table 1
Number of elements and nodes in each component of the model.

Element details Part	Element type	Number of elements
Cortical bone(outer layer)	C3D4	56,250
Cancellous bone	C3D4	18,346
Mucosa	C3D4	5655
Acrylic resin (denture)	C3D4	70,878
Titanium screw:1	C3D4	26,990
Titanium screw:2	C3D4	26,810
Titanium screw:3	C3D4	21,869
Titanium implant:1	C3D4	53,113
Titanium implant:2	C3D4	58,836
Titanium implant:3	C3D4	57,647
Gold alloy IV	C3D4	17,079
Magnet:1	C3D4	11,516
Rubber ring	C3D4	3734
Bar (3 implant)	C3D4	4280
Clips	C3D4	7273

unilateral vertical, oblique forces on the defect side. The highest von Mises stresses value (34.59 Mpa) was determined in the third load condition (oblique load on defect side) and was recorded at the mesiopalatal surface of the cortical bone around the first implant and

Table 2
Elastic properties of the material used in the study.

Material	Young's Modulus(G Pa)	Poisson's ratio	Reference
Cortical bone	14.0	0.3	[17]
Cancellous bone	1.5	0.3	[17]
Titanium grade 5	110	0.3	[11]
Mucosa	0.003	0.45	[17]
Acrylic resin	2.35	0.3	[17]
Gold alloy IV	99.3	0.3	[17]
Magnet (Ne/Bo/Fe alloy)	150	0.24	[18]
Rubber ring	0.005	0.45	[17]

was higher than caused by the first and second loading conditions. The highest stress values resulted from the first and second loading conditions and were 25.7 Mpa and 28.7 Mpa, respectively. The Maximum stresses on the second implant was 17.43 Mpa, located on the palatal surface under the third loading condition which is higher than the first, second loading (12.84 and 11.96 Mpa). The stress at the most posterior implant was small 12.84 Mpa, 9.75 Mpa and 11.65 Mpa respectively.

3.3. Outcome of model III (Obturator retained by three implants with bar and clips)

Von Mises stress in model II is shown in Fig. 10 under bilateral vertical forces on both sides and unilateral vertical, oblique forces on the defect side. The highest von Mises stresses value (56 Mpa) was determined in the third load condition (oblique load on defect side) and was recorded at the mesiopalatal surface of the cortical bone around the first implant and was higher than caused by the first and second loading conditions. The highest stress values resulted from the first and second loading conditions and were 41.1 Mpa and 46.3 Mpa, respectively. The Maximum stresses on the second implant was 18.56 Mpa, located on the

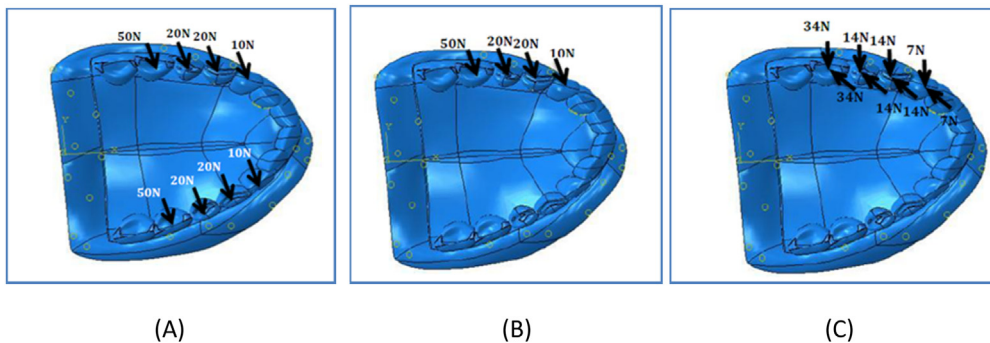

Fig. 7. A) Bilateral Vertical load of 100 N to the occlusal surface of posterior teeth. B) Unilateral Vertical load of 100 N to the occlusal surface of posterior teeth. C) Oblique load of 100 N is applied on the defected side.

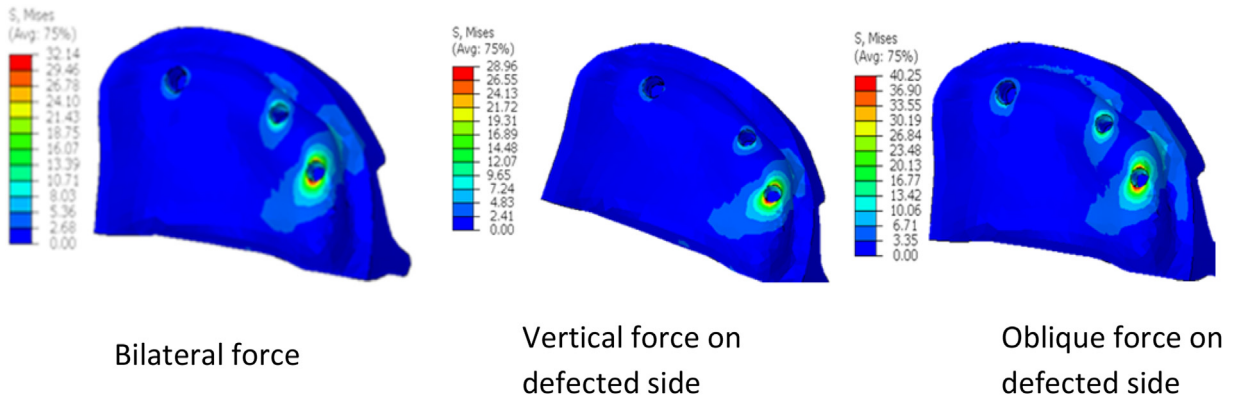

Fig. 8. Von Mises stress distribution in model I: ball & socket attachment.

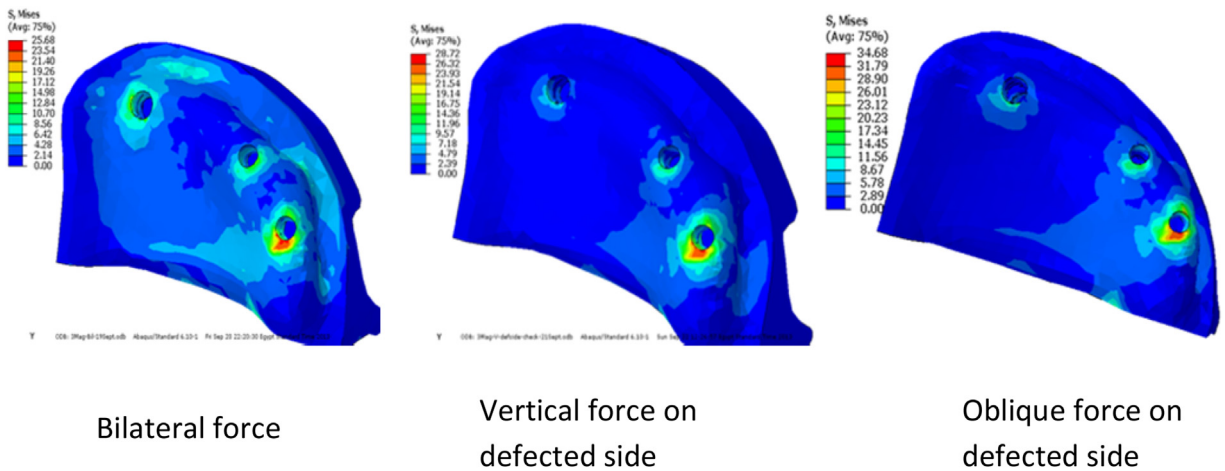

Fig. 9. Von Mises stress distribution in model II: magnet attachment.

palatal surface under the third loading condition which is higher than the first, second loading (11.57 and 10.28 Mpa). The stress at the most posterior implant was negligible 3.43 Mpa, 7.27 Mpa and 13.92 Mpa respectively.

3.3.1. Comparison between ball and socket, magnet and bar and clips attachments

The bar and clip attachment shows the highest stresses under different loading conditions as shown in Fig. 11.

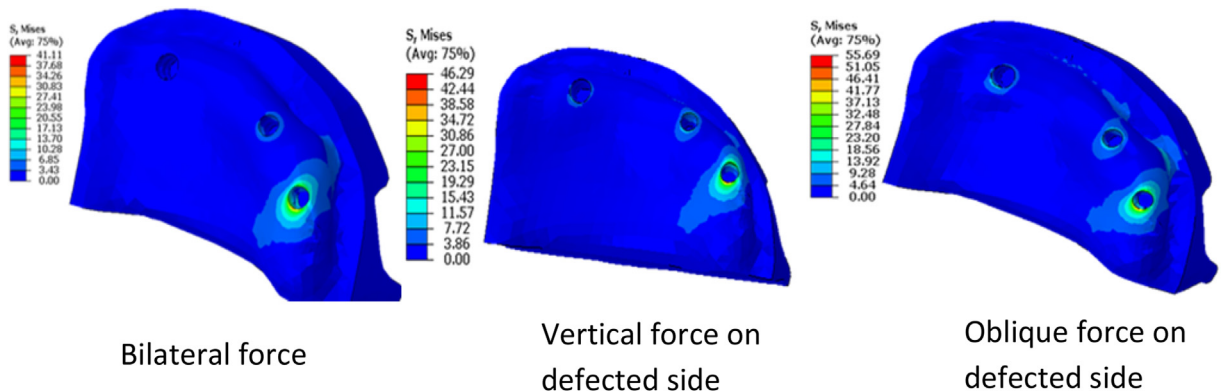

Fig. 10. Von Mises stress distribution in model III: bar & clip attachment.

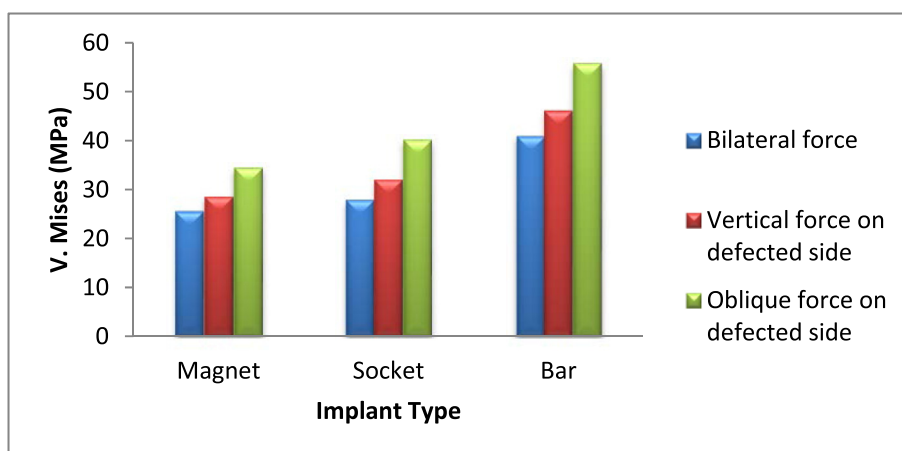

Fig. 11. Von Mises stresses in ball & socket, magnet and bar & clips models.

4. Discussion

The Maxillary defects resulting from cancer, trauma, and congenital malformation leading to changes in swallowing, speech, and mastication, decreasing drastically the life quality of these patients. The obturator prosthesis is frequently the choice of treatment because the complexity of maxillary and surgical reconstruction and uncertainty about restoration of the affected function [20–22].

However, it is known that stability and retention of maxillofacial obturator prosthesis are a challenge for most patients especially the edentulous patients, it varies according to the defect size and configuration and remaining contour of palate and soft tissues [22,23].

In order to solve this problem the use of osseointegrated implants as supporting components of prostheses provided a new rehabilitation alternative for those patients. Several attachment systems associated with the implants are frequently indicated for this kind of prosthesis, such as ball systems, bars and magnet [9].

Excessive stress at the implant–bone interface is among the potential causes of peri-implant bone loss and failure of osseointegration; hence, the estimation of the peak level of stress is of importance for the success of rehabilitation of implant-supported prostheses [19,24–26].

This study was conducted to evaluate stresses produced by using different types of attachments to retain obturator prosthesis for unilateral maxillary defect.

The FEA is a digital technique which is widely used in the fields of engineering and biomechanics. This method has been applied in the dental implant field for

prediction of stress distribution patterns in the implant–bone interface [11,25]. This allows not only comparison of various root form, length, and diameter implant designs but also modeling of various clinical scenarios and prosthesis designs, offering many advantages over the other methods [17,27]. Furthermore, the process of analysis is visual and vivid and allows the investigator to assess and examine any regions of interest [26,27].

Most of the failures related to total implant-retained prostheses happen due to the excess of stress transmitted to the implants and attachment systems which may cause fracture of the implants components or overload them and the surrounding bone tissue, which would also result in a possible loss of osseointegration [20].

It is well known that the geometry of bones have great effect on the accuracy of stress distribution, as well as the mechanical properties of materials, because those are the basis of FEA [11,19,22,28]. Many previous finite element studies were carried out with simplified block-shaped 3D models, or even 2D models, which could not represent the actual situation *in vivo* [29]. It is one of the advantages of our study that the model was constructed from impression taken from patient with midline defect, the nasal cavity and maxillary sinus were engraved in the model. So the model is nearly identical to the actual structures of human bones. Another advantage is actual modeling of the obturator prostheses, which previous FEA implant supported overdentures studies lack [17,29–31].

In this study loads are applied to the occlusal surface of the artificial teeth in order to simulate real masticatory load, the average biting force by implant patients is reported to be 50 N during chewing and

maximal bite force to be 145 N. Axial force component tend to increase distally in mouth. Molar bite-forces exceed four times the magnitude of bite-forces exerted in the anterior teeth region [32].

Load of 100 N was applied as also used previously [31,33–35]. Which is distributed on the posterior teeth 50 N on the first molar, 20 on each premolar, 10 N on canine, Vertical and oblique forces are applied to simulate the masticatory forces.

This study was a comparison between the most popular used attachment (ball and socket, magnet and bar and clip). The three types of attachment were selected from the same implant system (Dyna implant system) to avoid differences between different implant systems.

The implants are distributed along the alveolar ridge from anterior to posterior for more favorable load distribution [36] revealed that the distribution of bone stresses is more favorable with a spread-out implant arrangement than with a concentrated implant arrangement and cantilever restoration.

The results of this study showed that bar-clip attachments have the highest maximal stresses compared with unsplinted attachments (ball-socket and magnet) Fig 11.

Studies that compare different attachments used with implant assisted obturator are very rare. **Pesqueira et al**, used photoelastic stress analysis to assess stress distribution on implant retained obturators associated (with bar/clip and ball/O-ring) and an conventional obturators [37], The authors conclude that three individualized O-rings provided the lower values of stress in the implants and supporting tissues which is in agreement with the present study.

This result is in agreement with other studies that compare different attachments used with overdenture. In vivo studies [30,38], biomechanical studies using finite element (FE) [31], strain gauge [12,13], and photoelastic [8,9] analyses which displayed better stress distribution for overdentures retained by unsplinted implants while others showed superiority with the use of splinted implants [29,39–41].

Nevertheless, the results disagree with longitudinal prospective studies that showed no differences in marginal bone loss, peri-implantitis and implant survival rate in the two different attachment systems on two implants retaining an overdenture [42,43]. Also Stern and colleagues, through a series of three-dimensional force measurements with two infraforaminal Strauman implants in fully edentulous patients, showed no significant differences among different attachment assemblies and retention mechanisms [44].

Furthermore, another study concludes that the direction of occlusal forces is more influential than the connection of implants and that the difference in stress concentration between models with and without a bar is small [45]. In an *in vivo* study using a two-implant supported model, investigators observe that the attachment system may have less of an influence than other parameters, such as occlusion and superstructure fit, and may also determine type of implant loading [46].

Contrary to the rationale and theory of free rotation, recent data suggests that even if a bar that allows rotational movement, a higher load will transfer to the implants because of the difficulty to obtain optimum implant position, which would allow a pure rotational movement [47]. Therefore, a design should be in equilibrium between load of implant and denture bearing area.

When ball attachments was used, the force may be absorbed at the female component and head connection therefore, in long term, Prosthodontic complication such as screw loosening or the need to replace matrices may occur [48].

Independent connections to each implant abutment or continuous bar retainers are the most common approaches. In either case, retention and stability are provided primarily by implants through attachments, and support is shared by implants and edentulous posterior ridges [49].

The load direction affects the stresses values. The oblique load shows the most maximum of Von Mises among all models. This data suggested that it is important to minimize stress created by lateral forces by elimination of premature occlusal contacts, proper selection of an occlusal scheme, and wide distribution of stabilizing components.

Within cortical bone, peak of stresses was observed on the periimplant region. When the implant is loaded, the stress is transferred to its first material contact (i.e. periimplant cortical bone), which explains the clinical marginal bone loss around implants in agreement with [50] Correlation between high occlusal stress onto the implants and marginal bone loss has been showed. The higher stress values observed in cortical bone may rely on its higher elastic modulus when compared with trabecular bone [51]. The result of this study revealed highest maximal stresses around the most anterior implant.-this is in agreement with clinical studies that showed that the rate of marginal bone loss for implants next to the defect is higher than that for implants inserted posterior to them [3].

This may be due to the nature of obturator rotation during function; one side of the obturator is supported by the implants and residual ridge while the defect side rests on soft tissue, which is considered as a cantilever. For that reason it is recommended, whenever possible, to install wide and long implants in that position to have a predictable long term implant success in these cases.

5. Conclusions

Within the limitations of this study, it is concluded that the maximum stress around implants is affected by type of attachment used and direction, location of load application.

- 1) The oblique load showed the highest maximum of Von Mises stresses compared with bilateral and unilateral vertical load.
- 2) The most anterior implant (the nearest to the defect) showed higher stresses than the posterior implants.
- 3) Bar & clip models attachment showed the highest stresses among other types of attachment, the lowest stresses were observed with magnet attachment followed by the ball & socket attachment.

Acknowledgment

The authors would like to thank Dr. Mohammed Saad Kamel Academic Visitor at Imperial College London, Associate Professor of mechanical engineering, University of Helwan for his great help in the finite work in this study, they are grateful also to Dr. Sherif Elatriby lecturer of mechanical engineering, University of Helwan for his efforts in the formation of the three dimensional computerized models.

References

- [1] Robb GL, Marunick MT, Martin JW, Zlotolow IM. Midface reconstruction: surgical reconstruction versus prosthesis. *Head Neck J* 2001;23:48–58.
- [2] Wang RR. Sectional prosthesis for total maxillectomy patients: a clinical report. *J Prosthet Dent* 1997;78:241.
- [3] Roumanas ED, Nishimura RD, Davis BK, Beumer J. Clinical evaluation of implants retaining edentulous maxillary obturator prostheses. *J Prosthet Dent* 1997;77:184–90.
- [4] Keyf F. Obturator prostheses for hemimaxillectomy patients. *J Oral Rehabil* 2001;28:821–9.
- [5] Hobkirk J, Watson R, Searson L. *Introducing dental implants*. Michael Parkinson. 1st ed. London: Churchill Livingstone; 2003. pp: 120.
- [6] Sato Y, Shindoi N, Hosokawa K, Tsuga K, Akagawa Y. A biomechanical effect of wide implant placement and offset placement of three implants in the posterior partially edentulous region. *J Oral Rehabil* 2000;27:15–21.
- [7] Weinberg LA, Kruger B. A comparison of implant/prosthesis loading with four clinical variables. *Int J Prosthodont* 1995;8:421–33.
- [8] Kenney R, Richards M. Photoelastic stress patterns produced by implant-retained overdentures. *J Prosthet Dent* 1998;80:559–64.
- [9] Celik G, Uludag B. Photoelastic stress analysis of various retention mechanisms on 3-implant-retained mandibular overdentures. *J Prosthet Dent* 2007;97:229–35.
- [10] Eraslan O, Sevimay M, Usumez A, Eskitascioglu G. Effects of cantilever design and material on stress distribution in fixed partial dentures – a finite element analysis. *J Oral Rehab* 2005;32:273–8.
- [11] Himmlova L, Dostalova T, Kacovsky A, Konvickova S. Influence of implant length and diameter on stress distribution: a finite element analysis. *J Prosthet Dent* 2004;91:20–5.
- [12] Porter AJ, Petropoulos VC, Brunski JB. Comparison of load distribution for implant overdenture attachment. *Int J Oral Maxillofac Impl* 2002;17:651–62.
- [13] Tokuhisa M, Matsushita Y, Koyano K. In vitro study of a mandibular implant overdenture retained with ball, magnet, or bar attachments: comparison of load transfer and denture stability. *Int J Prosthodont* 2003;16:128–34.
- [14] Şahin S, Murat CC, Yalsin E. The influence of functional forces on the biomechanics of implant-supported prostheses—a review. *J Dent* 2002;30:271–82.
- [15] DeTolla DH, Andreana S, Patra A, Buhite R, Comella B. The role of the finite element model in dental implants. *J Oral Implant* 2000;26:77–81.
- [16] Feng YZ, Feng HH, Wu HI. Finite element analysis of stress distribution of obturator prostheses for acquired unilateral maxillary defects. *J Cent South Univ Technol* 2005;12:365–8.
- [17] Chun HJ, Park DN, Han CH, Heo SJ, Heo MS, Koak JY. Stress distributions in maxillary bone surroundings overdenture implants with different overdenture attachments. *J Oral Rehabil* 2005;32:193–205.
- [18] John J, Rangarajan V, Ravindra C, Savadi KS, Kumar S, Kumar BS. A finite element analysis of stress distribution in the bone, around the implant supporting a mandibular overdenture with Ball/O ring and magnetic attachment. *J Indian Prosthodont Soc* 2012;12:37–44.
- [19] Geng JP, Tan K, Liu GR. Application of finite element analysis in implant dentistry. *J Prosthet Dent* 2001;85:585–98.
- [20] Dilek OC, Tezulas E. A mini implant-supported obturator application in a patient with partial maxillectomy due to tumor: case report. *Oral Surg Oral Pathol Oral Radiol Endod* 2007;103:e6–10.
- [21] Goiato MC, Fernandes AU, dos Santos DM, Barão VA. Positioning magnets on a multiple/sectional maxillofacial prosthesis. *J Contemp Dent Pract* 2007;8:101–7.
- [22] Bagis B, Aydogan E, Hasanreisoglu U. Rehabilitation of a congenital palatal defect with a modified technique: a case report. *Cases J* 2008;1:39.
- [23] Prado Ribeiro P, Goiato MC, Pellizzer EP, Pesqueira AA, Haddad MF, Alves-Rezende, et al. Photoelastic stress analysis of different attachment systems on implant-retained and conventional palatal obturator prostheses. *J Craniofac Surg* 2011;22:523–6.

- [24] Branemark PI, Engstrand P, Ohnrell LO, Gröndahl K, Nilsson P, Hagberg K, et al. Branemark Novum. A new treatment concept for rehabilitation of the edentulous mandible. Preliminary results from a prospective clinical follow-up study. *Clin Implant Dent Relat Res* 1999;1:2–16.
- [25] Duyck J, Van Oosterwyck H, Vander Sloten J, De Cooman M, Puers R, Naert I. Magnitude and distribution of occlusal forces on oral implants supporting fixed prostheses: an in vivo study. *Clin Oral Implants Res* 2000;11:465–75.
- [26] Sadowsky SJ. Treatment considerations for maxillary implant overdentures: a systematic review. *J Prosthet Dent* 2007;97:340–8.
- [27] Bozkaya D, Muftu S, Muftu A. Evaluation of load transfer characteristics of five different implants in compact bone at different load levels by finite elements analysis. *J Prosthet Dent* 2004;92:523–30.
- [28] Korkmaz FM, Korkmaz YT, Yalug S, Korkmaz T. Impact of dental and zygomatic implants on stress distribution in maxillary defects: a 3-dimensional finite element analysis. *J Oral Implantol* 2012;38:557–67.
- [29] Assuncao WG, Tabata LF, VA Barão, Rocha EP. Comparison of stress distribution between complete denture and implant retained overdenture-2D FEA. *J Oral Rehabil* 2008;35:766–74.
- [30] Assuncao WG, Barão VA, Tabata LF, De Sousa EA, Gomes EA, Delben JA. Comparison between complete denture and implant-retained overdenture: effect of different mucosa thickness and resiliency on stress distribution. *Gerodontology* 2009;26:273–81.
- [31] Barao VA, Assuncao WG, Tabata LF, Delben JA, Gomes ÉA, de Sousa EA, et al. Finite element analysis to compare complete denture and implant-retained overdentures with different attachment systems. *J Craniofacial Surg* 2009;20:1066–71.
- [32] Brunski JB. Biomaterials and biomechanics in dental implant design. *Int J Oral Maxillofac Impl* 1988;3:85–97.
- [33] Cehreli MC, Iplikcioglu H, Bilir ÖG. The influence of the location of load transfer on strains around implants supporting four units of axial versus off-set loading. *J Oral Rehab* 2002;29:394–400.
- [34] Teixeira MF, Ramalho SA, de Mattias Sartori IA, Lehmann RB. Finite element analysis of 2 immediate loading systems in edentulous mandible: rigid and semi-rigid splinting of implants. *Implant Dent* 2010;19:39–49.
- [35] Barao VA, Delben JA, Lima J, Cabral T, Assuncao WG. Comparison of different designs of implant-retained overdentures and fixed full-arch implant-supported prosthesis on stress distribution in edentulous mandible – a computed tomography-based three-dimensional finite element analysis. *J Biomech* 2013;46:1312–20.
- [36] Benzig UR, Gall H, Weber H. Biomechanical aspects of two different implant- prosthetic concepts for edentulous maxillae. *Int J Oral Maxillofac Impl* 1995;10:188–98.
- [37] Pesqueira AA, Goiato MC, Santos DM, Nobrega AS, Haddad MF, Andreotti AM, et al. Stress analysis in oral obturators prostheses: imaging photoelastic. *J Biomed Opt* 2013;18.
- [38] Duyck J, Van Oosterwyck H, Van der Sloten J, De Cooman M, Puers R, Naert I. In vivo forces on oral implants supporting a mandibular overdenture: the influence of attachment system. *Clin Oral Investig* 1999;3:201–7.
- [39] Fanuscu MI, Caputo AA. Influence of attachment systems on load transfer of an implant-assisted maxillary overdenture. *J Prosthodont* 2004;13:214–20.
- [40] Cekic C, Akca K, Cehreli MC. Effects of attachment design on strains around implants supporting overdentures. *Quintessence Int* 2007;38:e291–7.
- [41] Jofre J, Cendoya P, Munoz P. Effect of splinting mini-implants on marginal bone loss: a biomechanical model and clinical randomized study with mandibular overdentures. *Int J Oral Maxillofac Implant* 2010;25:1137–44.
- [42] Chao YL, Meijer HJA, Van Oort R, Versteegh P. PA. The incomprehensible success of the implant stabilized overdenture in the edentulous mandible: a literature review on transfer of chewing forces to bone surrounding implants. *Eur J Prosthodont Restor Dent* 1995;3:255–61.
- [43] Mericske-Stern R. Three dimensional force measurements with mandibular overdentures connected to implants by ball-shaped retentive anchors. A clinical study. *Int J Oral Maxillofac Impl* 1998;13:36–43.
- [44] Mericske-Stern R, Piotti M, Sirtes G. 3-D in vivo force measurements on mandibular implants supporting overdentures. A comparative study. *Clin Oral Impl Res* 1996;7:387–96.
- [45] Jemt T, Chai J, Harnett Heath MR, Hutton JE, Johns RB. A 5-year prospective multicenter follow-up report on overdentures supported by osseointegrated implants. *Int J Oral Maxillofac Impl* 1996;11:291–8.
- [46] Jemt T. Implant treatment in resorbed edentulous upper jaws. *Clin Oral Implants Res* 1993;4:187–94.
- [47] Bergendahl T, Engquist B. Implant supported overdentures: a longitudinal prospective study. *Int J Oral Maxillofac Impl* 1998;13:253–62.
- [48] Payne AG, Solomons YF. The prosthodontic maintenance requirements of mandibular mucosa- and implant-supported overdentures: a review of the literature. *Int J Prosthodont* 2000;13:238–45.
- [49] Chan MFWY, Johnson C, Howell RA, Cowood JI. Prosthetic management of the atrophic mandible using endosseous implants and overdentures. *Br Dent J* 1995;179:329–37.
- [50] Isidor F. Influence of forces on peri-implant bone. *Clin Oral Implants Res* 2006;17(2):8–18.
- [51] Naert IE, Duyck JA, Hosny MM, Van Steenberghe D. Free standing and tooth-implant connected prostheses in the treatment of partially edentulous patients part II: an up to 15-years radiographic evaluation. *Clin Oral Implant Res* 2001;12:245–51.